



PUBLIC ADDRESS SYSTEM

OPERATION MANUAL

TC-4500
TC-4700
MIXER AMPLIFIER



Please follow the instructions in this manual to obtain the optimum results from this unit.
We also recommend that you keep this manual handy for future reference.

TABLE OF CONTENTS

1. SAFETY PRECAUTIONS	3
2. GENERAL DESCRIPTION	5
3. FEATURES	5
4. NOMENCLATURE AND FUNCTIONS	
4.1 Front Panel	6
4.2 Rear Panel.....	7
5. OPERATION ILLUSTRATION	8
6. TROUBLESHOOTING	12
7. BLOCK DIAGRAM	13
8.SPECIFICATIONS	14
9.DIMENSIONAL DIAGRAM	15

1. SAFETY PRECAUTIONS

- Be sure to read the instructions in this section carefully before use.
- Make sure to observe the instructions in this manual as the conventions of safety symbols and messages regarded as very important precautions are included.
- We also recommend you keep this instruction manual handy for future reference.

Safety Symbol and Message Conventions

Safety symbols and messages described below are used in this manual to prevent bodily injury and property damage which could result from mishandling. Before operating your product, read this manual first and understand the safety symbols and messages so you are thoroughly aware of the potential safety



WARNING

Indicates a potentially hazardous situation which, if mishandled, could result in death or serious personal injury.



CAUTION

Indicates a potentially hazardous situation which, if mishandled, could result in moderate or minor personal injury, and/or property damage.



WARNING

When Installing the Unit

- Do not expose the unit to rain or an environment where it may be splashed by water or other liquids, as doing so may result in fire or electric shock.
- Use the unit only with the voltage specified on the unit. Using a voltage higher than that which is specified may result in fire or electric shock.
- Do not cut, kink, otherwise damage nor modify the power supply cord. In addition, avoid using the power cord in close proximity to heaters, and never place heavy objects -- including the unit itself -- on the power cord, as doing so may result in fire or electric shock.
- Be sure to replace the unit's terminal cover after connection completion. Because high voltage is applied to the speaker terminals, never touch these terminals to avoid electric shock.
- Be sure to ground to the safety ground (earth) terminal to avoid electric shock. Never ground to a gas pipe as a catastrophic disaster may result.
- Avoid installing or mounting the unit in unstable locations, such as on a rickety table or a slanted surface. Doing so may result in the unit falling down, causing personal injury and/or property damage.

When the Unit is in Use

- Should the following irregularity be found during use, immediately switch off the power, disconnect the power supply plug from the AC outlet and contact your nearest **ITC** dealer. Make no further attempt to operate the unit in this condition as this may cause fire or electric shock.
 - If you detect smoke or a strange smell coming from the unit.
 - If water or any metallic object gets into the unit
 - If the unit falls, or the unit case breaks
 - If the power supply cord is damaged (exposure of the core, disconnection, etc.)
 - If it is malfunctioning (no tone sounds.)
- To prevent a fire or electric shock, never open nor remove the unit case as there are high voltage components inside the unit. Refer all servicing to your nearest **ITC** dealer.
- Do not place cups, bowls, or other containers of liquid or metallic objects on top of the unit. If they accidentally spill into the unit, this may cause a fire or electric shock.
- Do not insert nor drop metallic objects or flammable materials in the ventilation slots of the unit's cover, as this may result in fire or electric shock.

CAUTION

When Installing the Unit

- Never plug in nor remove the power supply plug with wet hands, as doing so may cause electric shock.
- When unplugging the power supply cord, be sure to grasp the power supply plug; never pull on the cord itself. Operating the unit with a damaged power supply cord may cause a fire or electric shock.
- When moving the unit, be sure to remove its power supply cord from the wall outlet. Moving the unit with the power cord connected to the outlet may cause damage to the power cord, resulting in fire or electric shock. When removing the power cord, be sure to hold its plug to pull.
- Do not block the ventilation slots in the unit's cover. Doing so may cause heat to build up inside the unit and result in fire.
- Avoid installing the unit in humid or dusty locations, in locations exposed to the direct sunlight, near the heaters, or in locations generating sooty smoke or steam as doing otherwise may result in fire or electric shock.

When the Unit is in Use

- Do not place heavy objects on the unit as this may cause it to fall or break which may result in personal injury and/or property damage. In addition, the object itself may fall off and cause injury and/or damage.
- Make sure that the volume control is set to minimum position before power is switched on. Loud noise produced at high volume when power is switched on can impair hearing.
- Do not operate the unit for an extended period of time with the sound distorting. This is an indication of a malfunction, which in turn can cause heat to generate and result in a fire.
- Contact your **ITC** dealer as to the cleaning. If dust is allowed to accumulate in the unit over a long period of time, a fire or damage to the unit may result.
- If dust accumulates on the power supply plug or in the wall AC outlet, a fire may result. Clean it periodically. In addition, insert the plug in the wall outlet securely.
- Switch off the power, and unplug the power supply plug from the AC outlet for safety purposes when cleaning or leaving the unit unused for 10 days or more. Doing otherwise may cause a fire or electric shock.

An all-pole mains switch with a contact separation of at least 3 mm in each pole shall be incorporated in the electrical installation of the building.

Due to product upgrades, while some of the features and specification in the user manual does not match the actual functions, sorry for any inconvenience and thanks for your kind understanding!

2. GENERAL DESCRIPTION

This series of products is the latest generation of high-power professional digital amplifiers, which is characterized by high efficiency, stability and excellent sound quality. It has broken through the traditional technology in power technology, modulation technology and control technology, so as to substantially improve the overall performance. The application of variable oscillator modulation technology, multiple feedback control technology and innovative output power control technology endow this series of amplifiers with over 95% ultra-high efficiency and excellent stability. And it is specially applicable to large-scale sound reinforcement venues, tour performance multipurpose halls, etc.

3. FEATURES

1. Built-in four-channel 4*500W/4*700W professional switched power supply digital amplifier;
2. Support DC, short circuit, overload and overheat protection;
3. Designed with Signal (green), CLIP (orange), Fault (red), Power (blue) indicators on the panel;
4. Support XLR balanced input; SPEAKON audio socket output;
5. Support signal, power, temperature and other voltage limiting functions;
6. Support optional three modes: MONO/STEREO/BRIDGE;
7. Support optional 1V/2V sensitivity;
8. With a temperature-controlled fan, it rotates as soon as it is turned on; the fan accelerates as the temperature rises, and reaches full speed at about 60°C;
9. Super load capacity: support 8 ohms, 4 ohms, and minimum 2 ohms.

4. NOMENCLATURE AND FUNCTIONS

4.1 FRONT PANEL

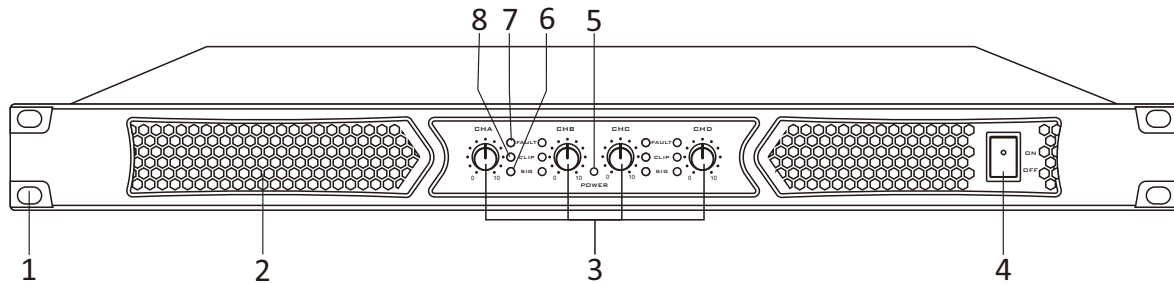

1. Cabinet fixing hole: used to fix the device when placed in the cabinet;
2. Air inlet: when the device is working normally, do not block the air from entering the device with objects;
3. CHA/CHB/CHC/CHD volume gain control to adjust the output amplitude of the amplifier;
4. Power switch: used to turn the power on and off, when it is switched to "ON", the power is turned on; when it is switched to "OFF", the power is turned off.
5. POWER--power indicator light, when the power switch is turned on, the indicator light will turn blue;
6. SIGNAL--signal indicator light, when the input signal exceeds "-32dB", the indicator light will turn green;
7. FAULT--fault indicator light, when the protection circuit starts, the indicator light will turn red;
8. CLIP--voltage limit indicator light, when the output signal distortion exceeds 1%, or when the power limiter starts, the indicator light will turn orange.

4. NOMENCLATURE AND FUNCTIONS

4.2 REAR PANEL

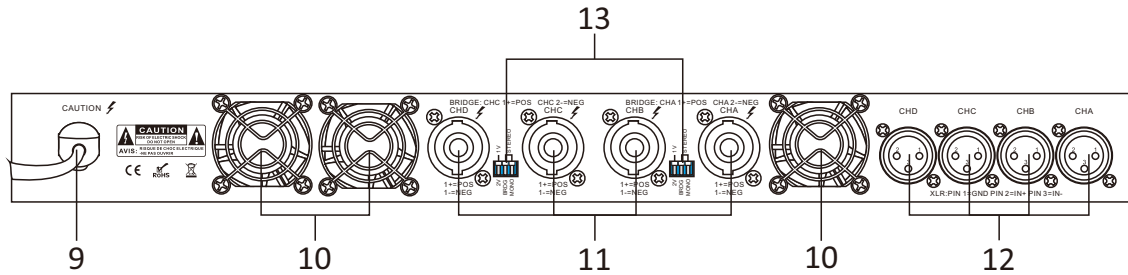

9. AC power input;

10. Cooling fan air outlet;

11. Amplifier output, four-core SPEAKON speaker plug:

① Stereo/mono mode output is CHA/CHB/CHC/CHD: 1+, 1-;

② Bridge mode output is CHA/CHC: 1+, 2-.

12. Signal input, input XLR female: balanced signal input connector;

13. Sensitivity/MONO/STEREO/BRIDGE mode switch:

① When the sensitivity switch is turned to 1V, the amplifier sensitivity is 2.2dB;

② When the sensitivity switch is turned to 2V, the amplifier sensitivity is 8.2dB;

③ When the mode switch is set to STEREO, it is stereo mode, and CHA, CHB, CHC, CHD channels work independently. The input signal of channel A is output through the output port of channel A; the input signal of channel B is output through the output port of channel B; the input signal of channel C is output through the output port of channel C; the input signal of channel D is output through the output port of channel D;

④ When the mode switch is turned to MONO/BRIDGE, it is mono mode/bridge mode; the signal input from the input port of channel A will be output through the output ports of channel A and B; the signal input from the input port of channel C will be output through the output ports of channel C and D.

5. OPERATION ILLUSTRATION



Before installation, please make sure that the power cord of the device is not connected to the power socket; the power switch is turned off; the volume knob is fully turned off (turn counterclockwise to the limit).

1. Power line



The grounding terminal of the AC power line should be well grounded, otherwise there is a danger of electric shock!

The AC power line must have sufficient over current capability, the AC power voltage must be within $\pm 10\%$ of the nominal operating voltage of the device, and the AC power frequency must be within the nominal frequency range of the device (the nominal value marked on the rear panel of the device).

2. Input and output lines

Wiring notes:

Use shielded wires for input signals as much as possible, and the higher the shielding layer density, the better.

Use balanced connections for input signals as much as possible to reduce noise interference.

If using an unbalanced connection, the wire should be as short as possible, preferably no more than 3m.

Weak signals should not go together with strong signal lines such as power lines and amplifier output lines, otherwise it may produce noise.

Turn off all equipment before changing any connections, as this may cause damage to your hearing and speakers.

3-pin XLR plug balanced connection, as shown below:

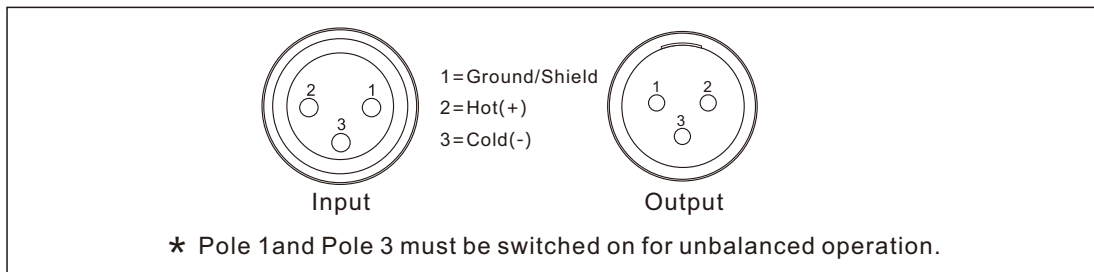

4-pin SPEAKON plug connection, as shown below:

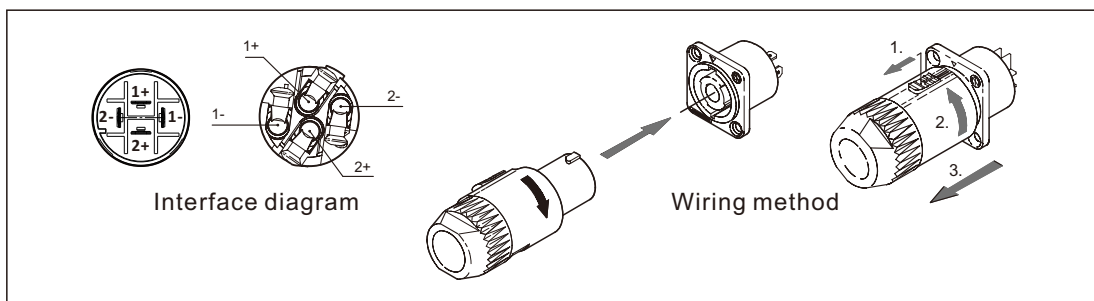

5. OPERATION ILLUSTRATION

2.1 Stereo Mode

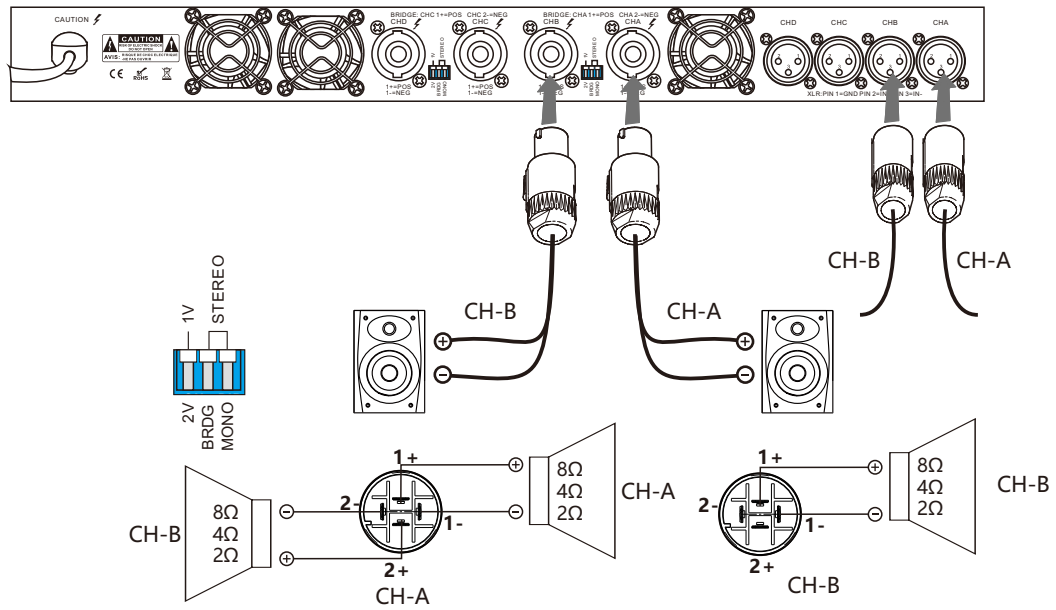

2.2 Mono Mode

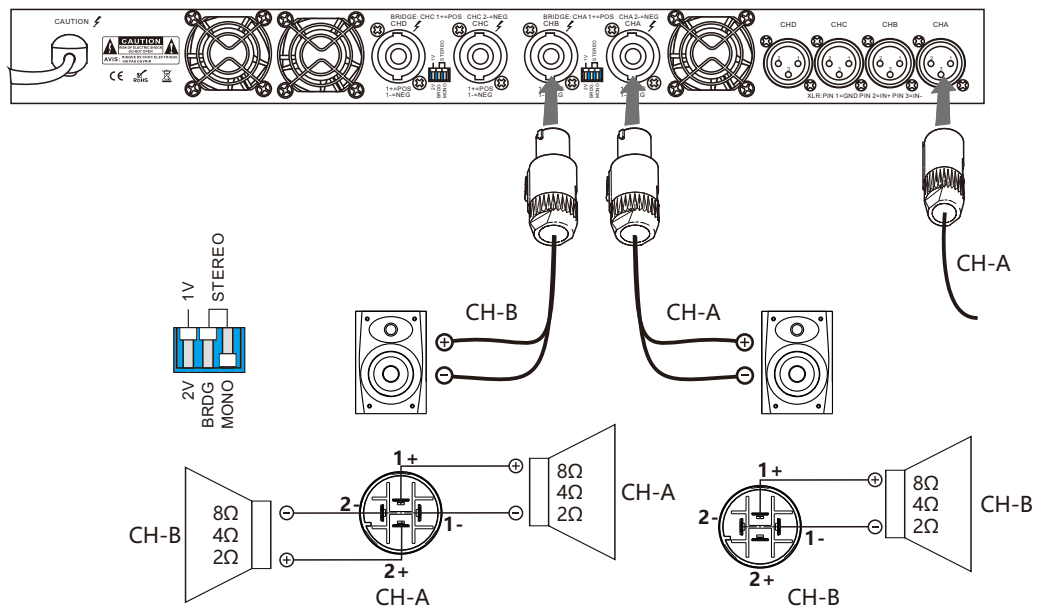

5. OPERATION ILLUSTRATION

2.3 Bridge Mode

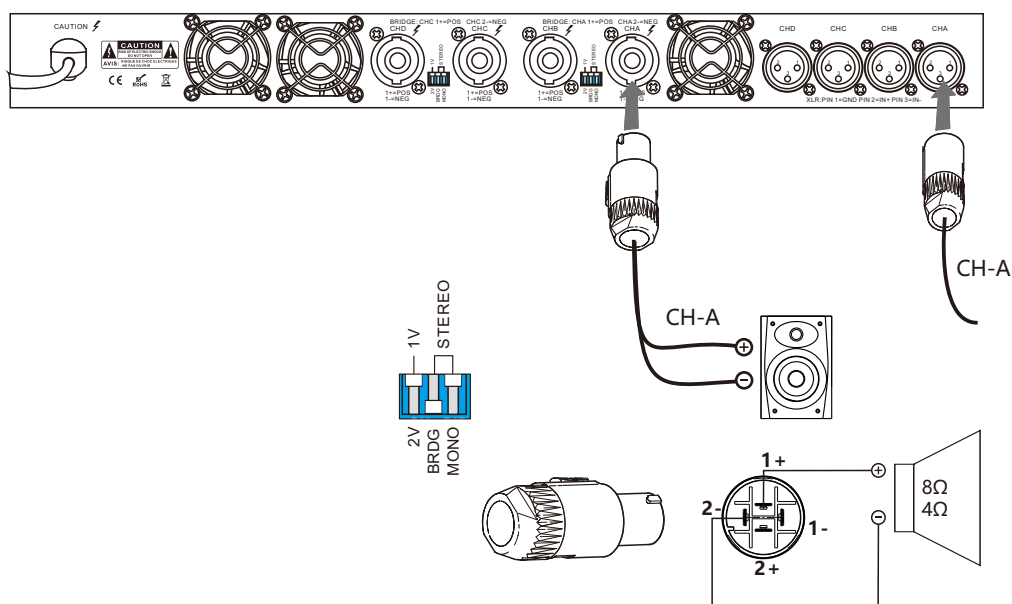

3. Speaker protection

Clipping not only makes the sound quality worse, but also damages the tweeter (once clipping, the CLIP indicator on the amplifier panel will light up, which can be used to determine whether there is clipping); you can reduce the input signal to avoid clipping.

A strong infrasound signal will cause the speaker drive circuit to burn out. Breathing sounds and high-level and low-frequency signals caused by the drop of the microphone are typical infrasound signals. To prevent infrasound signals, one of the following methods can be used:

a. Install a high-pass filter between the mixer output and the amplifier input;

b. Turn on the high-pass filter in the mixer. Set the filter frequency as high as possible without affecting usage. For example: set it to 35Hz for music signals, and set it to 75Hz for microphones. For each mixer input channel, set the filter frequency below the lowest basic frequency of the associated channel.

4. Usage precaution

Although the amplifier will be protected under abnormal conditions, in order to achieve the best performance and the highest security, please pay attention to:

- ① Before use, make some configurations for the amplifier, including the connection of input and output lines. Improper wiring can cause the device to not work properly.
- ② Take care when making connections, selecting input signals, and controlling output levels to avoid unnecessary troubles.

5. OPERATION ILLUSTRATION

- ③ Do not short-circuit the ground wire of the output cable and the ground wire of the input signal. Otherwise it may create a ground loop and causes oscillations.
- ④ Do not connect the output to power supply, battery, or main power. Failure to do so may result in electric shock.
- ⑤ Tampering with and unauthorized modification of circuits is dangerous and voids all dealer services.
- ⑥ Do not use the amplifier while the CLIP indicator keeps flashing.
- ⑦ Do not overload the mixer as this will send a clipped signal to the amplifier. The amplifier will accurately reproduce such signals and the speakers may be damaged.
- ⑧ Do not use the amplifier below the nominal load. Too low a load can damage the speaker by causing the amplifier output protection and premature clipping.
- ⑨ After the amplifier is turned on and a signal passes through, there may be a lethal voltage on the output interface.

5. Cooling instruction

The heat dissipation method of the device is as follows: cold air enters from the front panel vent, flows through the radiator inside the device and takes away the heat, and is discharged from the rear panel fan port. In order to ensure good heat dissipation, please place the device in an environment of 0°C-40°C, and make sure that the air ducts of the front and rear panels are unblocked.

If the temperature of the radiator inside the device exceeds 70°C, the power limit function will be activated, and the output power of the amplifier will be reduced to avoid temperature rise. If the temperature of the radiator continues to rise above 85°C, the amplifier will be protected and the output will be turned off. When the temperature drops to a safe temperature, the amplifier will automatically restart.

After using the device for a period of time (even if it is not turned on), if the fan runs at a high speed for a long time but the cooling effect is not good, please turn off the device and remove and clean the mesh cover (for devices with mesh cover).

Due to the high power density of this device and the strong magnetic field around the device, please keep away from weak signal sensitive devices as far as possible (preferably no less than 20cm), otherwise noise may be generated.

6. TROUBLESHOOTING

Failure phenomena	Failure cause
1. Power switch is not opened	<ol style="list-style-type: none">1. Power line is cut off2. The protection function of the equipment is not activated
2. All lines are connected, but there is no sound.	<ol style="list-style-type: none">1. No power or poor contact of the plug2. Burned fuse3. The volume knob is not turned on or switched to a too low level4. No audio signal input5. Speaker cable is short-circuited6. The device is set to a high-impedance connection, but the connected speakers adopt low-impedance inputs or too many speakers are connected
3. Low sound	The device is set to a low-impedance connection, but the connected speakers adopt high-impedance inputs.
4. Sound is distorted	The input level of the microphone or external device is too high.
5. The protection light is on	<ol style="list-style-type: none">1. The internal temperature of the device is too high2. Output channel short circuit protection

7. BLOCK DIAGRAM

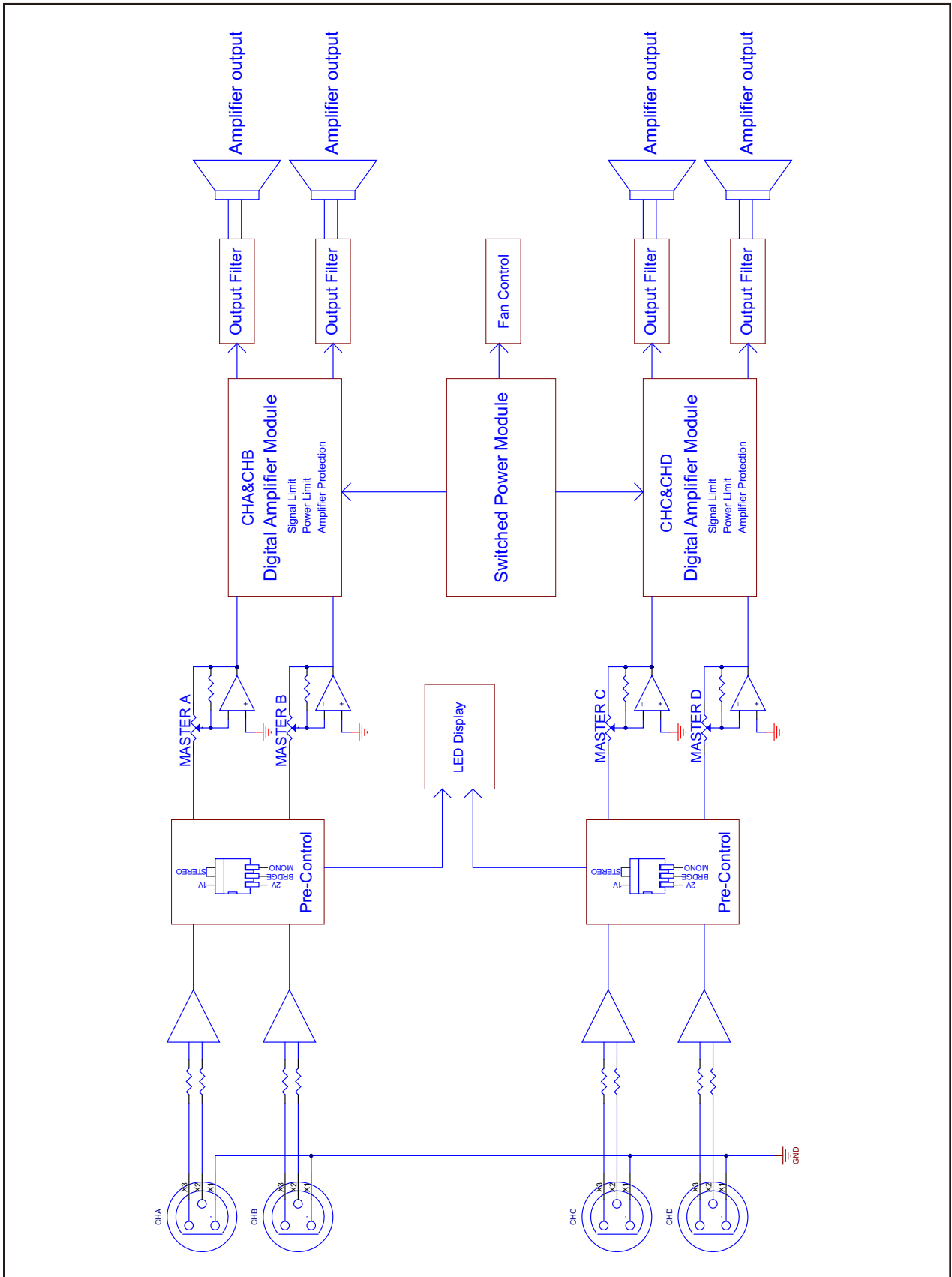

8. SPECIFICATIONS

Specification	Model	TC-4500	TC-4700
Output power (1kHz/THD≤1%)	Stereo 8Ω	4×500W	4×700W
	Stereo 4Ω	4×800W	4×1200W
	Stereo 2Ω	4×1300W	4×2250W
	Bridge 16Ω	2×1000W	2×1400W
	Bridge 8Ω	2×1600W	2×2400W
	Bridge 4Ω	2×2600W	2×4500W
Connecting plug	XLR interface		
Voltage gain (@1KHz)	36dB	37.5dB	
Input sensitivity	2.2dBu(1V)、8.2dBu(2V)		
Input impedance	10KΩ unbalanced, 20KΩ balanced		
Frequency response (@1W power)	20Hz-20KHz/±1dB		
THD+N (@1/8 power)	≤0.01%		
SNR(A-weighted)	≥102dB		
Damping coefficient (@ 1KHz)	≥200@8 Ohms		
Isolation (@1KHz)	≥85dB		
Protection method	Over voltage protection, under voltage protection, over current protection, DC protection, short circuit protection		
Indicator light	Power, Protection, Signal, Clip		
Cooling method	Fan cooling		
Power supply	<input type="checkbox"/> ~110V 50Hz <input type="checkbox"/> ~110V 60Hz <input type="checkbox"/> ~120V 50Hz <input type="checkbox"/> ~120V 60Hz <input type="checkbox"/> ~220V 50Hz <input type="checkbox"/> ~220V 60Hz <input type="checkbox"/> ~230V 50Hz <input type="checkbox"/> ~230V 60Hz <input type="checkbox"/> ~240V 50Hz <input type="checkbox"/> ~240V 60Hz		
Maximum power consumption	2500W	3200W	
Dimension (L×W×H)	484x370x44mm		
Weight	7.8Kg	8Kg	
*This power is measured according to the CEA-2006-B/CEA-490-A standard using a 20ms pulsed 1KHz sine wave at 1% total harmonic distortion.			

9. DIMENSIONAL DIAGRAM

UNIT:mm

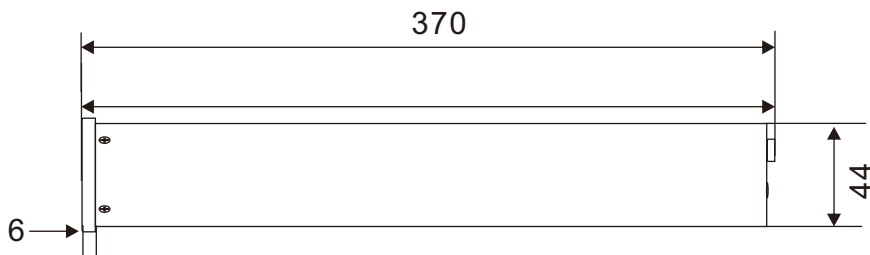
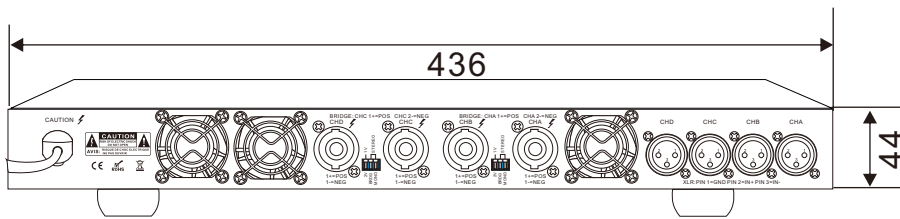
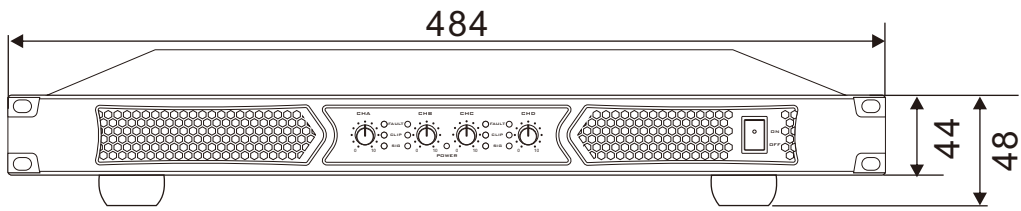

Keep the unit's all sides over 10 cm away from objects that may obstruct air flow to prevent the unit's internal temperature rise.

UNIT:mm

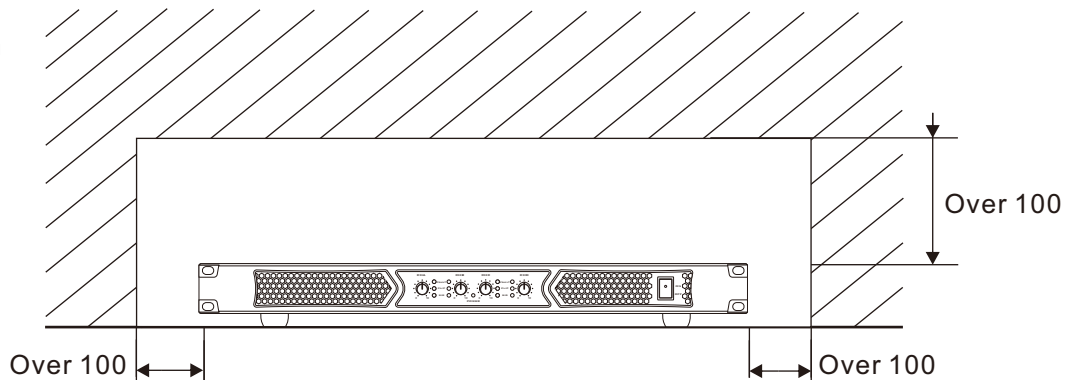

PUBLIC ADDRESS SYSTEM

